

General information

- ✓ In accordance with the S.M.A.C.N.A.
- ✓ Base material using for dampers is stainless steel 304, 316L or galv. steel
- ✓ Welding: Longitudinal seams shall be fusion welded. Traverse seams shall be continuous weld
- ✓ Various lengths available (minimal length 140 mm)



Control:



- manually operated (standard)



- automatically operated (on request)

SMACNA DAMPERS

3D MODEL:

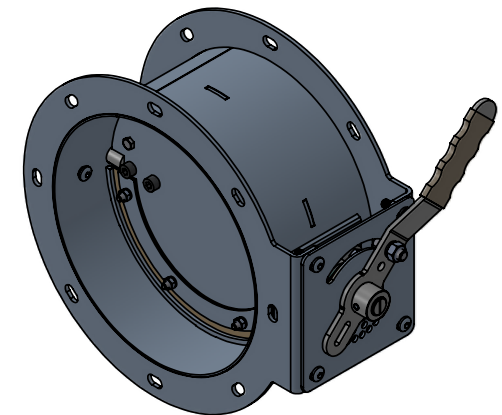

Let Us do it for You!

For more information visit our website or contact us



info@venttrade.eu



www.venttrade.eu



Abrahama 1A/2.01
80-307 Gdańsk
Poland